

Silva® Care

Product Range

Silvalea Ltd, a division of  **savaria.**





Since 1993, Silvalea has been at the forefront of the patient sling market, designing and manufacturing a wide portfolio of transfer solutions. Our speciality is our complex patient transfer slings and in-situ slings, as well as providing a range of everyday standard slings, transfer accessories and stand-assist transfer products. The comprehensive offerings of Silvalea are founded in over 30 years of innovation in fabric and design with both caregiver and patient in mind.

Today, Silvalea is proudly part of the Savaria Corporation with North American distribution of its products through the Savaria group of companies.

Whether the need is complex or an off-the-shelf sling, Silvalea has a solution. Now, Silvalea are delighted to be able to offer the new Silva® Care range featuring the *Air Comfort V2* chair and accessories.

For more information on the products featured in this brochure, please visit our website or contact us using the details below.

customerservices@silvalea.com
+44 (0)330 024 1045

silvalea.com

Contents

Silva® Care	2
Silva® Care Accessories	4
Foot Rest	5
Lap Belt	6
Meal Tray	7
Bolster	8
Product Training	10
Savaria Hoists	12
Silvalea Slings	14

145cm

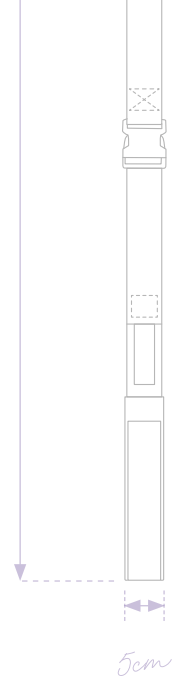

5cm

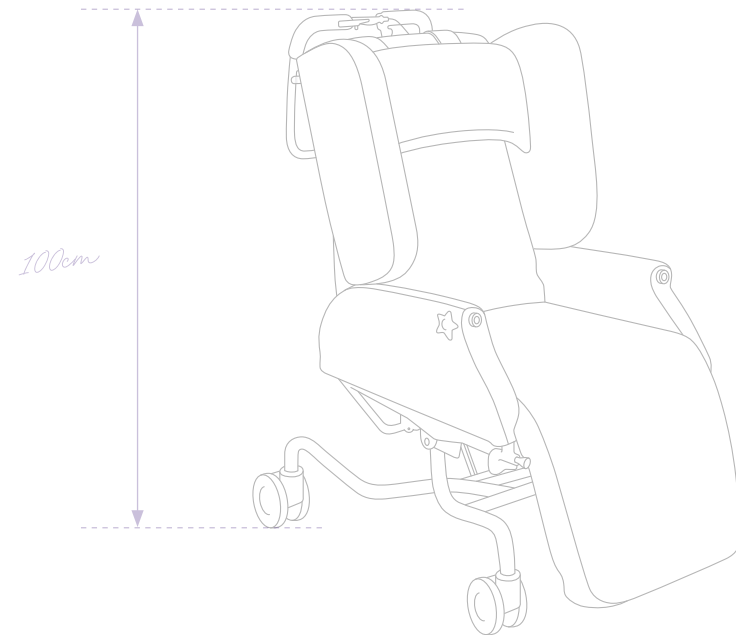

100cm

Silva® Care

Silva® Care by Silvalea is our new home of high-end equipment distributed exclusively by Silvalea to compliment our patient handling sling portfolio.

The equipment chosen will be in line with our highest standards of quality and our internal technical team will ensure all guidelines in manufacturing and design are met, giving peace of mind to our global distribution partners and patients.

This new range of complimentary equipment will be formed over the coming years as we source and develop the best possible solutions for our partners throughout the world.

customerservices@silvalea.com
+44 (0)330 024 1045

silvalea.com

Air Comfort Deluxe V2 Chair

- Patented Airgonomic Seating System providing comfort and pressure redistribution
- Adjustable back recline, seat tilt and leg rest
- Fully adjustable wings and drop down arms for easy side transfers
- Adjustable and removable head rest
- 3 x locking castors and 1 x locking directional castor
- Replaceable covers and parts
- Wipe clean with mild disinfectant wipes
- Accessories such as meal tray, foot rest, lap belt and bolster also available



SC-CHAIR

Product Codes & Specifications



	PVC and Polyester	SWL	A (Seat Width)	B (Overall length)
Small	SC-CHAIR-SML	180kg/392lb/28st	43cm	100cm
Standard	SC-CHAIR-SND	180kg/392lb/28st	47cm	113cm
Maxi	SC-CHAIR-MAXI	300kg/661lb/47st	72cm	136cm



Small



Standard and Maxi



Silva® Care Accessories

Introducing a range of innovative accessories specially designed to enhance the *Air Comfort Deluxe V2* chair, delivering an unmatched level of comfort and taking the patient experience to new heights.

These meticulously crafted additions not only enhance the overall experience for patients but also offer valuable options for unsurpassed comfort.

With a diverse selection of options available, we are confident that our array of accessories will cater to the unique needs and preferences of each individual, guaranteeing a truly positive experience during their time in the *Air Comfort Deluxe V2* chair.

customerservices@silvalea.com
+44 (0)330 024 1045

silvalea.com



Foot Rest

- Fully adjustable
- Soft foam for comfort
- Easy wipe clean surface
- Colour match material
- Flip up pads
- Removable covers

AO59055, AO59053

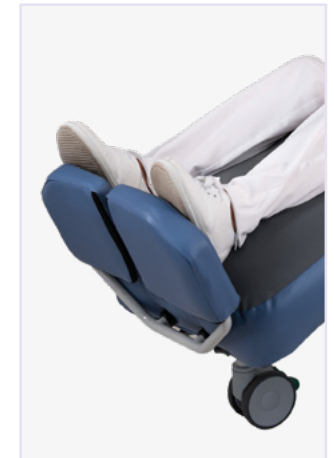

Product Codes & Specifications



	PVC and Polyester	A	B
Small	AO59055	45cm	21cm
Standard	AO59055	45cm	21cm
Maxi	AO59053	68cm	35cm

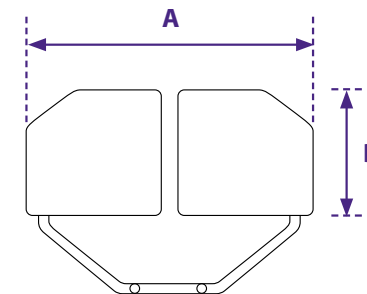

Lap Belt

- Simple to attach
- Hook and Loop fastening
- Clunk-Click buckle closure
- Adjustable
- Detachable quilted cover giving comfort from the Clunk-Click buckle



LSTRAP

Product Codes & Specifications

	100% Polyester webbing	A	B
Small	LSTRAP-SML	145cm	5cm
Standard	LSTRAP-SND	180cm	5cm
Maxi	LSTRAP-MAXI	250cm	5cm

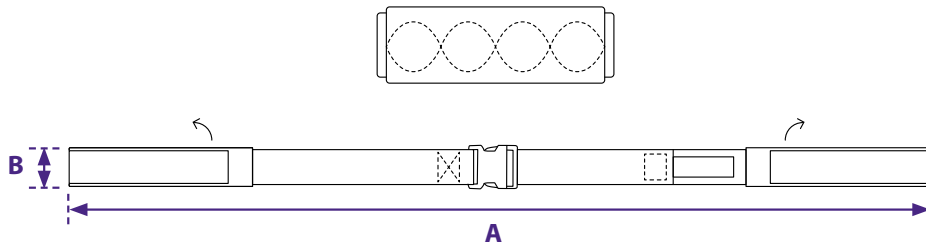

Meal Tray

- Formed plastic top with anti-drip rim
- Moulded drinks area
- Adjustable table fittings
- Folds for easy storage
- Easy wipe clean surface



AO59036/5, AO59007

Product Codes & Specifications

	Laminated wood	A	B
Small	AO59036	72cm	37cm
Standard	AO59035	72cm	37cm
Maxi	AO59007	100cm	32cm

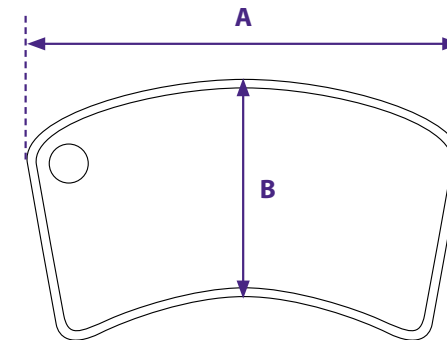

Bolster

- Padded roll bolster
- Offers extra support for additional postural stability
- Manufactured in Dartex
- Wipe clean with a mild disinfectant
- Available in 2 sizes (1m and 2m)

BOLSTER



Product Codes & Specifications



	Polyurethane	A	B
1	BOLSTER-1	100cm	15cm
2	BOLSTER-2	200cm	15cm

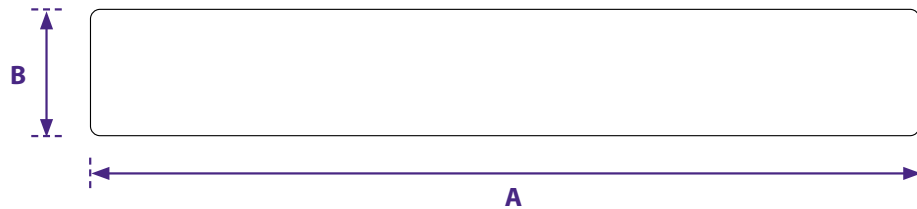

Discover our
Silva® Care
Product Range





Product Training

Silvalea has been offering **product training and assessment** support for over 30 years.

From our purpose-built studio—complete with gantry and mobile hoists, along with a full range of slings—training and demonstrations can be delivered via various streaming platforms straight to your device, wherever you may be. Our varied sessions cover all styles and applications along with more detailed user applications.

These live and interactive sessions enable us to communicate directly and in real-time providing a valuable resource to clients around the world.

Our e-assessments can be organised quickly and efficiently, to a time suitable for you and your patient enabling us to assist with complex scenarios and discuss options.

Subscribe to our YouTube channel for our latest training videos.

 [youtube.com/@SilvaleaLtdYT](https://www.youtube.com/@SilvaleaLtdYT)

customerservices@silvalea.com
+44 (0)330 024 1045

[silvalea.com](https://www.silvalea.com)

Product Guidance and Technical Advice



Product training
and assessment
support for over
30 YEARS



Hoists by Savaria

Designed by long time industry experts, our R&D team knew that we could make a better product by looking at the details and questioning how to improve everything.

Savaria hoists offer faster lift speeds, are powerfully light—up to 35% lighter than leading competitors—and incredibly strong.

The SureClip system by Savaria opens out providing a more foolproof method of securing a sling to the portable hoist or spreader bar of the fixed hoist. A simple, but powerful detail for added safety.

Our hoists and controls are intuitive from the first touch with simple, clear buttons to move the lift up, down or side to side. Without extraneous electronics to break down or cause user confusion, the hoist elegantly and reliably performs its tasks.

For more information on the products featured on this page, please visit our website or contact us using the details below.

customerservices@silvalea.com
+44 (0)330 024 1045

silvalea.com





Slings

Silvalea offers a range of slings designed for different hoist models and patient needs.

Our Loop Fixing Slings, suitable for coat hanger hoists, offer flexibility with colour-coded loops for precise positioning and Silva-Safety Slots® for enhanced safety and reduced bulk.



Our Clip Fixing Slings are compatible with various hoist models, featuring a safety "Click-on Click-off" mechanism for secure attachment and durable internal parts.

Additionally, our Bariatric Slings, part of the Silvalea Bariatric Product Range, have been designed to address challenges and offer options in all aspects of care and have been carefully selected to offer a full transfer solution to healthcare professionals.



customerservices@silvalea.com
+44 (0)330 024 1045

silvalea.com



Authorised Dealer or Partner



Silvalea Ltd, Silverhills Buildings, Decoy Industrial Estate,
Newton Abbot, Devon, TQ12 5LZ, United Kingdom

E: customerservices@silvalea.com

T: +44 (0)330 024 1045

W: silvalea.com

Registration Number: 04350939 | VAT Number: GB797412786

Silvalea Ltd, a division of  **savarica**
Copyright © 2024 | All Rights Reserved